

# MOVANO Caged Tipper – Recognised Conversion

European Whole Vehicle Type Approval TBC (In progress)



Available as an additional cage conversion to existing Movano tippers or as a lightweight tipper and cage conversion to chassis or crew cab models, the Movano caged tipper is ideal for municipal recycling, aboricultural and forestry applications. The 2.0m high cage is fitted with 270° opening rear doors, full-height nearside sliding side-access door (all load doors fitted with retainers) and 50mm x 50mm galvanised mesh.

The five-stage, chrome-plated under floor ram provides a 50° tip angle employing a high performance, 2kW electro-hydraulic power pack which can be operated via a cab-mounted, spiral wander-lead.



A 2.0m high cage with 50mm x 50mm galvanised mesh is fitted as standard.



Five-stage ram provides a 50° tip angle.



500kg tail lift is available as an option at extra cost.

## Unique/key selling points

- › Powder-coated and wax injected steel box section construction
- › Lightweight galvanised mesh cage
- › Steel platform, powder coated in dark grey
- › Roofless design for ease of loading
- › 270° opening/lockable rear doors

## Vauxhall recognised conversions

These conversions have been tested to ensure they meet the technical standards required by General Motors UK Limited.

### Movano Caged Tipper

EC WVTA in process with completion planned for April 2013.

## Typical cage conversion features

- › Option 1 – cage only conversion applied to core conversion tipper
- › Option 2 – tipper and cage conversion applied to standard chassis cab
- › Powder-coated and wax injected steel box section construction
- › 50mm x 50mm galvanised mesh, powder coated and attached to frames after painting, to enhance corrosion resistance
- › Rear header bar with end outline LED marker lights
- › Roofless design for ease of loading
- › 270° opening/lockable rear doors
- › Handle, latches and door retainers highlighted in 'Traffic' yellow
- › Overall height decal in cab

## Conversion options (at extra cost)

- › Utility cab conversion – based on crew cab, second-row seats removed, lining and bulkhead added and windows fitted with aluminium sheet
- › 25mm x 25mm mesh in lieu of 50mm x 50mm
- › Offside full-height sliding doors with retainers
- › Detachable rear header bar
- › 1.2m high cage
- › Cage extension for use with tail lift
- › 500kg 'dump-over' tail lift with 765mm deep folding aluminium platform
- › Steel mesh roof (50mm x 50mm or 25mm x 25mm)
- › Sliding cargo net type roof
- › Selection of beacons, light-bars and toolboxes
- › Chapter 8 compliant livery

## Please note

Typical conversion examples shown. Conversions on other model variants are available please consult the converter. Full specification, option and colour availability details of the Movano range appear in the Movano brochure available from your Vauxhall retailer or Lo-call 0845 600 1500. Alternatively, details can be found on our website at [www.vauxhall.co.uk/vans](http://www.vauxhall.co.uk/vans)



### Converter contact details:

For conversion pricing, option and warranty details contact:  
VFS (Southampton) Limited, Unit 8, Barton Park Industrial Estate,  
Chickenhall Lane, Eastleigh, Hants SO50 6RR  
Email: [jamesh@vfs.co.uk](mailto:jamesh@vfs.co.uk) Website: [www.vfs.co.uk](http://www.vfs.co.uk) Tel: 02380 613612

VFS is a wholly owned subsidiary of Scattolini SpA.

## L2 H1 RWD HD Caged Tipper Dimensions mm (in.)

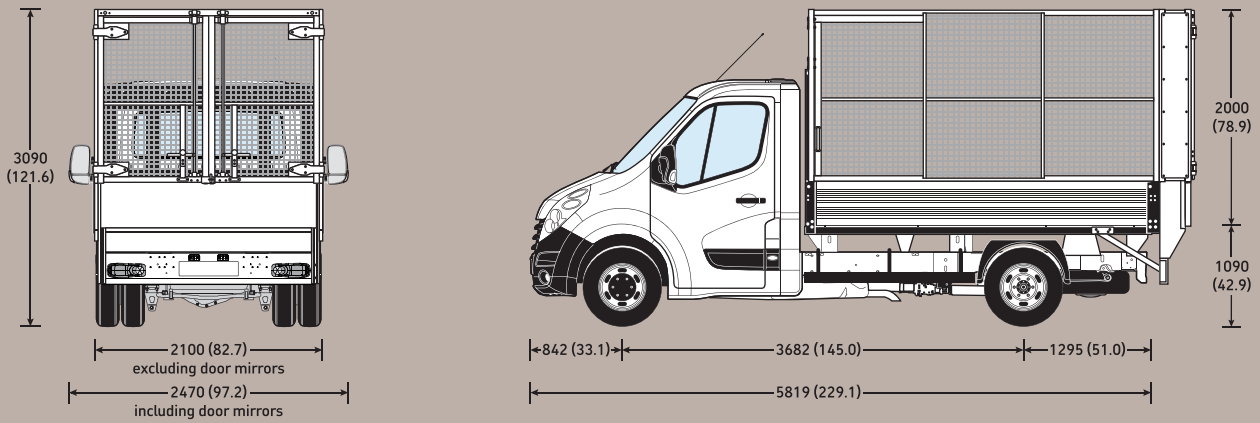

## Load area dimensions mm

Load lengths	3105-3205
Maximum height (to top of cage)	2000
Height (side and rear panels)	400
Maximum width	2040
<b>Load area volumes cu.m. (cu.ft)</b>	
L3 (including L3 RWD Crew Cab)	12.7 (448)
L2 (and L3 FWD Crew Cab)	13.1 (463)



## Weights kg

Typical examples*	UK plated weights and kerbweights				
	Front axle	Rear axle	GVW	Kerb	Payload
L2 H1 R3500HD 2.3CDTI 16v	1850	2300	3500	3076	424
L2 H1 R4500HD 2.3CDTI 16v	1850	3200	4500	3076	1424

**\*Please note:** Dependent on model, typical examples shown above. Calculations based upon models currently available as Core Conversion Tipplers. **Kerbweights** include conversion body weight (inc. Tail lift), coolant, oil, 90% full fuel tank and spare wheel. They will vary according to the vehicle specification (including options and accessories) with a corresponding variation in payload. **Payload** figures do not allow for the weight of the driver, or any passengers, which should therefore be deducted from the figures shown. **Gross plated weights** (including axle weights) quoted on the vehicle plated must never be exceeded.

Every effort has been made to ensure that the contents of this publication were accurate and up-to-date at the time of publication (February 2013). Vauxhall vehicles are equipped with components manufactured by various General Motors operating units and outside suppliers. The Company reserves the right to alter specifications and withdraw products from sale without notice. Any such alterations will be notified to Vauxhall retailers at the earliest opportunity, please consult your local retailer for the latest information. The specifications detailed within this brochure are not necessarily applicable to alternative models such as Special Editions. Details of any such models will be contained in specific literature or found on the Vauxhall website. Please note that Vauxhall retailers are not the agents of General Motors UK Limited and are not authorised to bind the Company by any specific or implied undertaking or representation. It is advisable to ensure that your motor insurance policy provides adequate cover for additional fitted options and accessories. Please note accessories shown are for illustrative purposes only. All rights reserved. No part of this publication may be reproduced in any form or by any means, without the prior written permission of General Motors UK Limited.

V1 ©2013 General Motors UK Limited Published March 2013 General Motors UK Limited, Luton LU1 3YT



**COMMERCIAL VEHICLES**  
The Wheels of Business

**VAUXHALL**